

Seasonal changes in abundance, biomass and depth distribution of mesozooplankton community in Kagoshima Bay

Masato MINOWA¹, Toru KOBARI^{1†}, Hiroyasu AKAMATSU¹, Toshihiro ICHIKAWA²,
Ryuji FUKUDA³ and Masataka HIGASHI⁴

Seasonal changes in abundance, biomass and depth distribution of mesozooplankton community were investigated in Kagoshima Bay, to evaluate how mesozooplankton affect sinking flux of particulate organic carbon (POC). Chlorophyll *a* concentrations were low in March and higher than 1 mg m^{-3} in August and November when micro-sized phytoplankton was predominated. Mesozooplankton biomass and abundance were uniform throughout the water column in March, while they were concentrated above 50 m in the other months. In March, mesozooplankton larger than 2 mm contributed to their biomass and the most predominant group was of calanoid copepods. In the other months, metazoans smaller than 0.5 mm dominated the community biomass and poecilostomatoid copepods were the most predominant. Based on a box model, mesozooplankton feeding composed only 16 to 33% of primary production in August and November when POC fluxes at 150 m were higher than those in the other months. These results indicate that the high POC fluxes in August and November are resulted from the sinking aggregates of large phytoplankton cells which are not effectively removed by small copepods.

Key words: mesozooplankton, abundance, biomass, depth distribution, vertical carbon flux, Kagoshima Bay

Introduction

It has been long accepted that sinking particles are major pathway of vertical carbon flux into the deep layers and support underlying carbon demand of zooplankton community (Fowler and Knauer, 1986; Zhang and Dam, 1997; Yamaguchi et al., 2002). Zooplankton fecal pellets are an important component of sinking particles (Lampitt et al., 1990; Silver and Gowing, 1991; Carroll et al., 1998; Turner, 2002). It has been reported that fecal pellets are declined with ingestion (coprophagy) of micro- and mesozooplankton (González and Smetacek, 1994; Svendsen and Nejtgaard, 2003; Huskin et al., 2004; Poulsen and Kiørboe, 2006) and/or are fragmented by swimming and sloppy feeding (coprorhexy) of small copepod community (Iversen and Poulsen, 2007; Kobari et al., 2010).

Kagoshima Bay is a large semi-enclosed embayment

located at the southernmost part of Kyushu, Japan. This embayment is divided by a narrow and shallow channel, which is formed by a volcano Mt. Sakurajima, into the northern and southern areas. The two areas are characterized by deep topography more than 200 m. In this deep and semi-enclosed embayment, hypoxia less than $2 \text{ mO}_2 \text{ l}^{-1}$ was sometimes measured in the deep layers during late summer to autumn (<http://www.pref.kagoshima.jp/kurashikankyo/kankyo/suishitu/sokutei/index.html>). In general, hypoxia at the coastal sites is formed by sinking of the phytoplankton stock over the zooplankton ingestion at surface and consumption of dissolved oxygen by bacterial decomposition at the depth during summer stratification (e.g. Takahashi et al., 2000; Tsutsumi et al., 2007). Sometimes, such hypoxia results in negative impacts on coastal fishery resources (e.g. Zaitsev, 1992). However, we have little knowledge how and why the hypoxia is formed during late summer to autumn in Kagoshima Bay.

In the present study, we hypothesize that the decline of sinking particulate organic carbon (POC) flux is associated with depth distribution and taxonomic composition of mesozooplankton community. Thus, we investigated seasonal changes in depth distributions of abundance, biomass and community structure for mesozooplankton in Kagoshima Bay. From these results, we discuss how sinking POC is affected through ingestion and egestion of mesozooplankton community using a box model.

Received May 30, 2010; Accepted December 28, 2010.

¹ Fisheries Biology and Oceanography Division, Faculty of Fisheries, Kagoshima University, 4–50–20 Shimoarata, Kagoshima, Kagoshima 890–0056, Japan

² Department of Earth and Environment Science, Faculty of Science, Kagoshima University, 1–21–24 Korimoto, Kagoshima, Kagoshima 890–8580, Japan

³ T/S Nansei-Marui, Faculty of Fisheries, Kagoshima University, 4–50–20 Shimoarata, Kagoshima, Kagoshima 890–0056, Japan

⁴ T/S Kagoshima-Marui, Faculty of Fisheries, Kagoshima University, 4–50–20 Shimoarata, Kagoshima, Kagoshima 890–0056, Japan

† kobari@fish.kagoshima-u.ac.jp

Materials and Methods

Oceanographic observations

Oceanographic observations were carried out in 10 to 11 March, 23 to 24 June, 19 to 20 August and 18 to 19 November 2008 at Station A (31°24'N, 130°38'E, 220-m deep) in Kagoshima Bay, southwestern Japan (Fig. 1) during the cruises of the T/S Nansei-Marui. Temperature and salinity were recorded from the sea surface to a depth of 210 m using a CTD system (Seabird SBE-9). Water samples for chlorophyll and dissolved oxygen measurements were collected from 11 depths (10, 20, 30, 40, 50, 75, 100, 125, 150, 200 and 210 m) with a CTD-CMS system and from sea surface with a plastic bucket. These samples were filtered through a nitex plankton net (20- μ m mesh opening), a Millipore polycarbonate membrane filter (5- μ m pore size) and a Whatman GF/F filter (0.7- μ m pore size) under vacuum pressure less than 20 kPa. Thereafter, chlorophyll pigments on the three filters were immediately extracted by direct immersion into *N,N*-dimethylformamide (DMF) at -5°C in darkness for more than 24 h (Suzuki and Ishimaru, 1990). Chlorophyll *a* concentration was measured with a fluorometer (Turner Designs Co., TD-700) by the non-acidified fluorometric method (Welschmeyer, 1994). Size-fractionated chlorophyll *a* was indicated as micro- (>20 μ m), nano- (5–20 μ m) and pico-sized phytoplankton (0.7–5 μ m). Dissolved oxygen was determined by the Winkler titration method.

Zooplankton collections and identification

Zooplankton samples were collected with a Vertical Multiple Plankton Sampler (0.25-m² mouth square, 0.1-mm mesh size; Terazaki and Tomatsu, 1997) at 1 m s⁻¹ during both day (09:00–11:00) and night (22:00–0:00) at each cruise. The following discrete depth intervals were sampled on the upcast: 0–50, 50–100, 100–150 and 150–210 m. Net tow samples were split using a Folsom plankton splitter and subsamples were processed using protocols similar to Steinberg et al. (2008a). Both subsamples were fractionated into five size categories (0.1–0.2, 0.2–0.5, 0.5–1.0, 1.0–2.0, >2.0-mm) using nested sieves. The first halves of subsamples at each size category were preserved in borax-buffered 5% formaldehyde-seawater solution for enumeration of major taxa. Under a stereo dissecting microscope (Nikon SMZ1200), zooplankton was identified into forty-four taxonomic groups (Table 1). For copepods which were predominant group, adult and copepodite specimens were identified into 23 families following Chihara and Murano (1997) and nauplii were categorized as other mesozooplankton. The other halves of subsamples were transferred onto pre-weighed 0.1-mm nitex mesh filters and preserved at -20°C after rinsed with distilled water until weight measurement. These samples were freeze-dried for 1 h at -50°C (Eyela FDU-1200) and dried for 24 h at 60°C (Advantec FS-620).

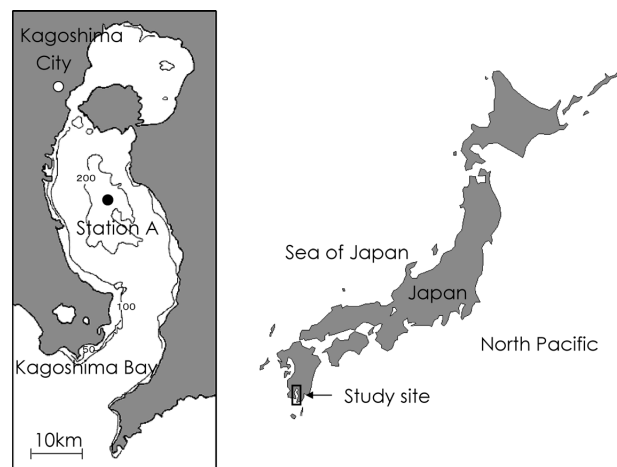

Figure 1. Sampling station (Station A) in Kagoshima Bay. Black lines with numerals show bathymetric contours.

Dry weights of zooplankton for each size fraction were measured on a micro balance (Sartorius CP2202S).

Mesozooplankton ingestion and egestion

Metabolic rates (oxygen consumption rates) of mesozooplankton in each layer were calculated from the observed *in situ* temperature and averaged animal dry mass of mesozooplankton according to the following equation (Ikeda, 1985)

$$\ln R = -0.2512 + 0.7886 \ln B + 0.049T \quad (1)$$

where R is the oxygen consumption rate (μO_2 individual⁻¹ h⁻¹), B is the average animal dry weight (mg individual⁻¹) and T is integrated mean temperature ($^{\circ}\text{C}$) of each sampling stratum. The averaged animal dry weight was calculated from dry weight measurement and the microscopic counts of mesozooplankton of each size class. R was computed by summing of animal R in each size class. In the present study, we assumed that R is not affected by depth (cf. Thuesen et al., 1998). R was converted to carbon units assuming a respiratory quotient ($[\text{CO}_2]/[\text{O}_2]$) of 0.97 (protein metabolism, cf. Gnaiger, 1983). Carbon budgets of mesozooplankton may be expressed as:

$$ZCD = R + G + M + E \quad (2)$$

where ZCD is mesozooplankton carbon demand (i.e. ingestion on both phytoplankton and other particles), R is respiration, G is growth, M is molts and E is egestion. Assuming 0.6 for assimilation efficiency ($AE: E = (1 - 0.6) ZCD$) and 0.3 for gross growth efficiency ($GGE: 0.3 ZCD = G + M$) which are median values for mesozooplankton (Omori and Ikeda, 1976), ZCD can be approximated as:

$$ZCD = R/0.3 \quad (3)$$

We performed a sensitivity analysis for the calculation of zooplankton ingestion rate, using a lower ($AE: 0.7$, $GGE: 0.25$) and upper ($AE: 0.5$, $GGE: 0.35$) estimate of combined parameters, as reported by Steinberg et al. (2008b) and

Table 1. Monthly changes in taxonomic composition of mesozooplankton community (abundance-based: %). Feeding habit is based on Ohtsuka and Nishida (1997) and Chihara and Murano (1997). Numbers with underline show total composition of each feeding-habit group.

Taxon					Abundance-based composition (%)			
Phylum	Class	Order	Family	Mar.	June	Aug.	Nov.	
Suspension feeder				<u>78.56</u>	<u>92.27</u>	<u>93.87</u>	<u>82.22</u>	
Arthropoda								
Cladocera				<0.01	0.65	1.39	–	
Copepoda								
Calanoida								
Acartiidae				<0.01	0.13	0.29	0.12	
Aetideidae				–	<0.01	<0.01	0.01	
Calanidae				1.10	0.17	0.38	0.47	
Calocalanidae				0.26	2.25	2.77	0.28	
Clausocalanidae				2.47	4.46	2.65	3.13	
Eucalanidae				0.01	0.01	0.20	0.27	
Heterorhabdidae				–	–	–	–	
Lucicutiidae				0.09	0.85	0.75	3.13	
Metridinidae				<0.01	<0.01	<0.01	<0.01	
Paracalanidae				33.74	6.64	3.39	6.14	
Pontellidae				–	<0.01	0.06	0.13	
Scolecitrichidae				0.01	0.06	0.09	0.07	
Stephidae				<0.01	0.03	0.06	0.23	
Temoridae				–	0.03	0.57	0.53	
Tharybidae				–	–	–	<0.01	
Cyclopoida								
Oithonidae				9.28	16.41	11.25	7.07	
Harpacticoida								
Clytemnestridae				<0.01	0.11	0.01	0.02	
Ectinosomatidae				0.75	3.25	3.08	8.69	
Harpacticidae				–	–	0.06	<0.01	
Miraciidae				0.00	0.04	<0.01	<0.01	
Euterpinidae				–	0.03	4.20	4.93	
Poecilostomatoida								
Corycaeidae				1.68	1.62	0.22	0.70	
Oncaeidae				28.66	52.62	44.29	40.41	
Sapphirinidae				–	–	<0.01	0.02	
Malacostraca								
Mysidacea				<0.01	<0.01	<0.01	<0.01	
Euphausiacea				<0.01	<0.01	<0.01	<0.01	
Decapoda				<0.01	–	0.04	0.03	
Chordata								
Appendicularia				<0.01	–	–	0.82	
Thaliacea				–	–	0.05	<0.01	
Mollusca				0.51	2.91	18.07	4.98	
Carnivorous				<u>1.20</u>	<u>0.40</u>	<u>1.25</u>	<u>1.98</u>	
Arthropoda								
Copepoda								
Calanoida								
Candaciidae				0.01	<0.01	0.01	0.09	
Euchaetidae				0.15	0.12	0.09	1.07	
Chaetognatha				0.40	0.19	1.00	0.77	
Cnidaria				0.64	0.08	0.14	0.02	

Table 1. continued.

Taxon					Abundance-based composition (%)			
Phylum	Class	Order	Family	Mar.	June	Aug.	Nov.	
Ctenophora				–	0.00	–	0.01	
Malacostraca								
	Amphipoda			<0.01	–	0.01	0.02	
Omnivorous				<u>0.05</u>	<u>0.67</u>	<u>1.13</u>	<u>1.08</u>	
Annelida								
	Polychaeta			0.04	0.66	1.02	0.89	
Arthropoda								
		Ostracoda		0.01	0.01	0.11	0.18	
Dinoflagellata								
	Noctiluiphyceae			1.57	<0.01	–	–	
Unknown				<u>18.61</u>	<u>6.65</u>	<u>4.26</u>	<u>14.72</u>	
Foraminifera				0.19	0.12	0.12	0.68	
Radiolaria				–	<0.01	–	<0.01	
Other zooplankton				18.43	6.54	4.14	14.05	

Kobari et al. (2008). Carbon demands of the copepod community were estimated by summing the products of carbon demand and abundance of each size category.

To evaluate the effects of mesozooplankton ingestion and egestion to sinking particulate organic carbon (POC), we computed a “box model” as used by Sasaki et al. (1988). Basic assumptions associated with the model were as follows:

1. POC flux is decreased as the equation of Martin et al. (1987),
2. The rate of flux attenuation is assumed to be 1.33 (Buesseler et al., 2007),
3. Primary production is estimated in the water column with high chlorophyll (i.e. 30 m) backward from POC flux at 150 m measured by sediment trap (Kobari et al., 2010),
4. Sinking POC within a certain depth is intercepted and consumed by particle-feeding mesozooplankton in the underlying layer,
5. Feces produced within a certain depth range contribute to the POC flux in the underlying layer.

Feeding habits (particle-feeders, carnivorous, others) of each taxonomic group of mesozooplankton were based on Chihara and Murano (1997) and Ohtsuka and Nishida (1997). Feeding habits were assumed to be same to adults for copepodites and unknown for nauplii.

Results

Environments

Sea surface temperature ranged from 15.9°C in March to 30.0°C in August (Fig. 2). Vertical profiles of water temper-

ature and salinity showed that water column was mixing in March and seasonal stratification was developed above 50 m by warm and less saline waters covered with surface layers in June, August and November. Especially, less saline waters were evident in June. Dissolved oxygen was high throughout the water column in March and was decreased below 100-m depth toward November. It reached a minimum (3.58 ml l^{-1}) at near bottom in November. Chlorophyll *a* concentrations were below 1 mg m^{-3} throughout the water column in March. In June, August and November, chlorophyll *a* higher than 1 mg m^{-3} was found in the surface layers shallower than 30 m. Chlorophyll *a* maximum depth was sea surface in March and June, 20 m in August and 10 m in November. Nano-sized phytoplankton contributed to total chlorophyll *a* concentrations in March and June, while micro-sized phytoplankton was the most predominant component in high chlorophyll depths in August and November.

Seasonal changes

Throughout the study period, particle-feeders (mostly copepods) composed more than 79% of mesozooplankton abundance (Table 1). In March, paracalanids and oncaeids contributed to 34% and 29% of mesozooplankton abundance, respectively. Oncaeids were the most predominant group in the other months and oithonids were the next in June and August.

Mesozooplankton biomass (dry mass) in the water column above 210 m was a maximum up to 5.6 g m^{-2} in March and decreased gradually toward November (Fig. 3). In November, it reached a minimum to 3.2 g m^{-2} . In March, metazoans from 1 to 2 mm contributed to the mesozooplankton biomass. Size class between 0.2 and 0.5 mm was

Seasonal changes of zooplankton community in Kagoshima Bay

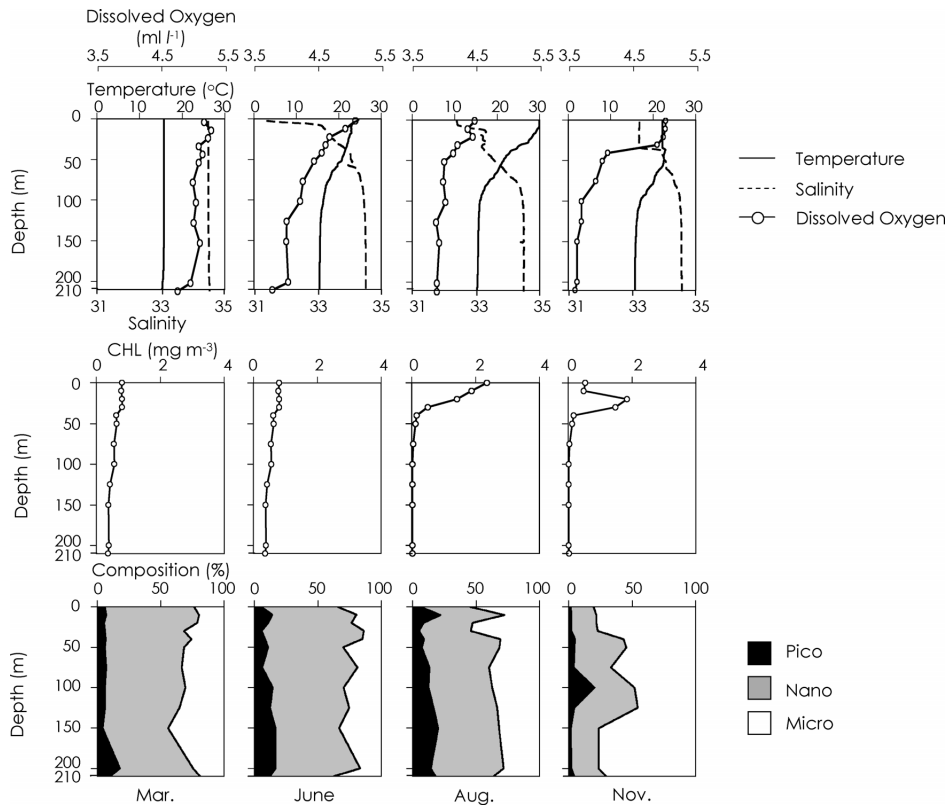

Figure 2. Seasonal changes in vertical profiles of temperature (WT, solid line at top panel: °C), salinity (SAL, broken line at top panel: PSU), dissolved oxygen (DO, circle at top panel: $ml\ l^{-1}$), chlorophyll *a* concentration (CHL, solid line at middle panel: $mg\ m^{-3}$) and its size composition (bottom panel: %) at Station A in Kagoshima Bay.

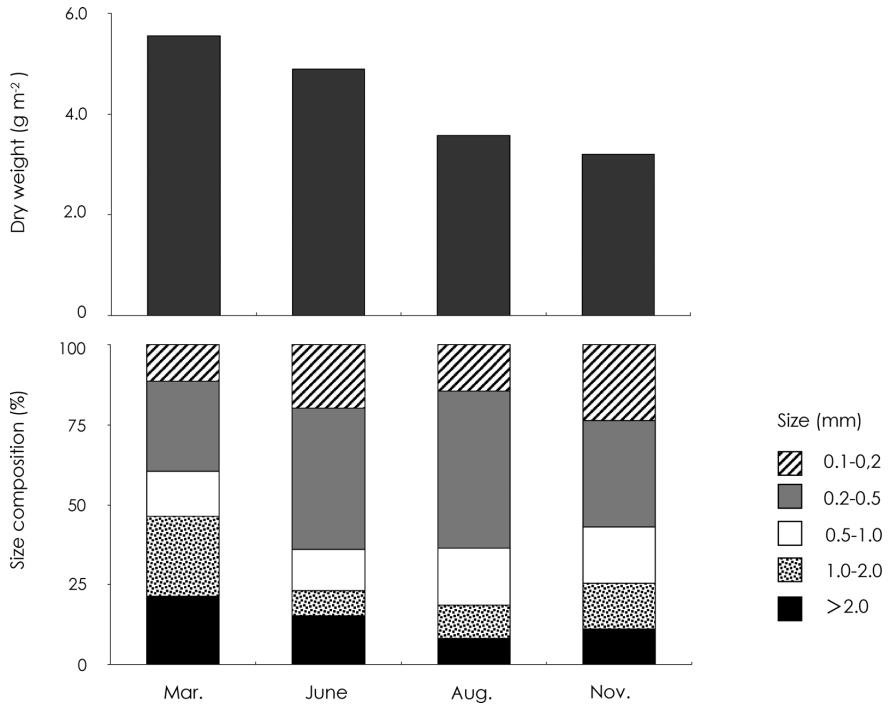

Figure 3. Seasonal changes in dry mass (upper panel: $mg\ m^{-2}$) and its size composition (bottom panel: %) of mesozooplankton in the water column from sea surface to 210 m at Station A in Kagoshima Bay.

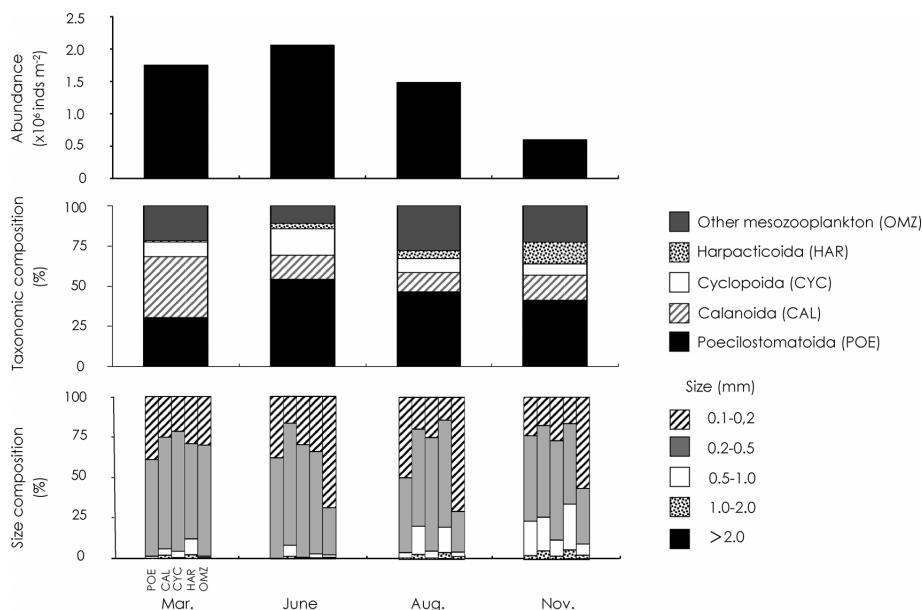

Figure 4. Seasonal changes in abundance (upper panel: 10^6 individuals m^{-2}), its taxonomic composition (middle panel: %) of mesozooplankton and size-class composition of dominant group (bottom panel: %) in the water column from sea surface to 210 m at Station A in Kagoshima Bay.

the most predominant component and metazoans smaller than 0.5 mm composed more than half of the total biomass in June, August and November.

Mesozooplankton abundance in the whole water column showed a different pattern from the biomass and reached a maximum more than 2.0×10^6 individuals m^{-2} in June (Fig. 4). It decreased thereafter and reached a minimum to 0.6×10^6 individuals m^{-2} in November. Copepods including calanoid, cyclopoid, harpacticoid and poecilostomatoid were predominant among mesozooplankton community, which were more than 74% of mesozooplankton abundance throughout the study period. The most predominant group was calanoid in March and poecilostomatoid in June, August and November. Poecilostomatoids composed more than 30% of mesozooplankton abundance and were responsible for the seasonal changes. Most of the specimens for each copepod group appeared abundantly size class smaller than 0.5 mm, indicating smaller copepods were dominated throughout the study period.

Depth distribution

Mesozooplankton biomass was relatively uniform throughout the water column in March, compared with those in the other months (Fig. 5). Mesozooplankton biomass concentrated above 50 m throughout the day in June, August and November when chlorophyll *a* was higher than 1 mg m^{-3} . In March, the predominant components were metazoans larger than 1.0 mm throughout the water column. Animals smaller than 0.5 mm composed more than 50% of total biomass above 50 m in June, August and November.

Depth distribution of mesozooplankton abundance was also uniform in March, compared with those in other months (Fig. 6). Mesozooplankton occurred abundantly above 50 m throughout the day in June, August and November. In March, calanoid copepods were the most predominant group throughout the water column and more abundant in the deeper layers. Poecilostomatoids were the next and increased their abundance in the shallower layers. In the other months, poecilostomatoids were predominant group throughout the water column. As exceptions, cyclopoids contributed to mesozooplankton abundance in 50–100 m in August and harpacticoids were abundant below 50 m during night in November. Obvious day–night migrations were not found for all taxonomic groups.

POC flux via mesozooplankton

We estimated impacts of mesozooplankton ingestion and egestion on POC flux using a box model (Fig. 7). POC flux at 150 m reached up to $264.4 \text{ mg C m}^{-2} \text{ day}^{-1}$ in August and slightly decreased to $241.1 \text{ mg C m}^{-2} \text{ day}^{-1}$ in November. Primary production estimated from POC flux at 150 m reached a maximum ($2.2 \text{ g C m}^{-2} \text{ day}^{-1}$) in August and was the lowest ($0.7 \text{ g C m}^{-2} \text{ day}^{-1}$) in March. Suspending-particle feeders accounted for more than 77% of total mesozooplankton abundance in 0–50 m layer. In the uppermost layer, their feeding impacts composed 16 to 53% of primary production. In the bottom layer, the feeding impacts of particle-feeders on POC flux was relatively low ($<33\%$) in August and November rather than those ($>79\%$) in March and June. Contribution of egestion (i.e. fecal pellets)

Seasonal changes of zooplankton community in Kagoshima Bay

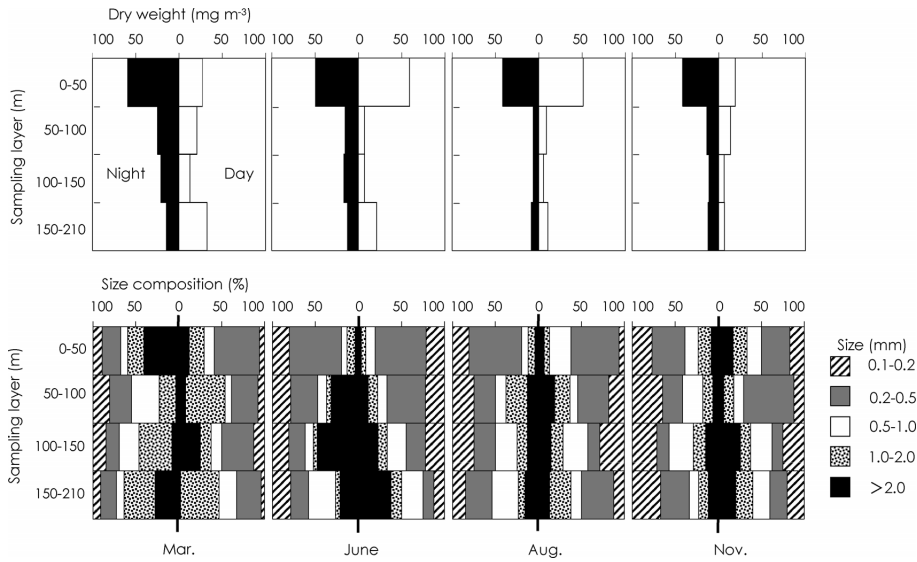

Figure 5. Seasonal changes in depth distribution of dry mass (upper panel: mg m^{-3}) and its size composition (bottom panel: %) for mesozooplankton in each sampling layer at Station A in Kagoshima Bay.

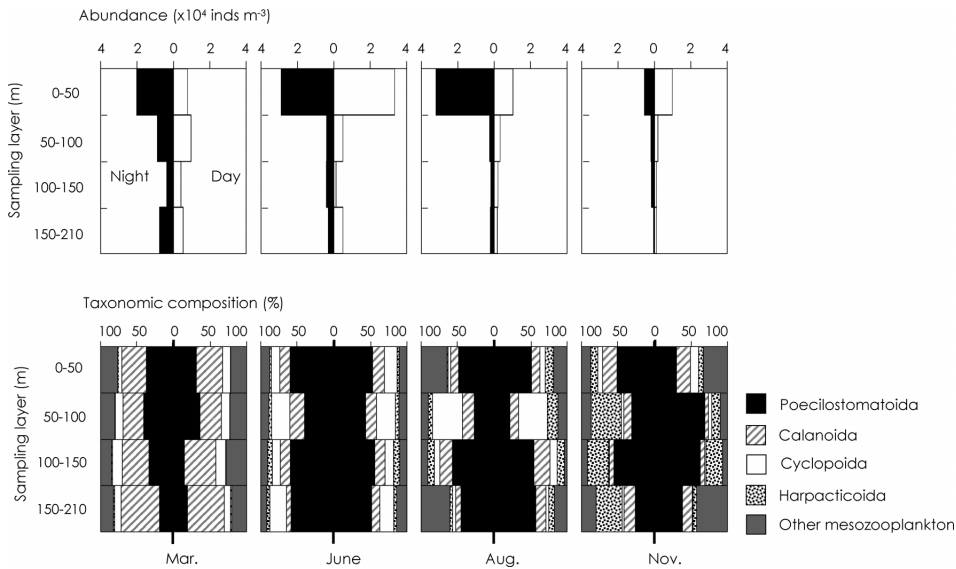

Figure 6. Seasonal changes in depth distribution of abundance (upper panel: 10^6 individuals m^{-2}) and its taxonomic composition (bottom panel: %) for mesozooplankton in each sampling layer at Station A in Kagoshima Bay.

to POC flux was also low (<23%) of in the layers below 50 m in August and November.

Discussion

Mesozooplankton abundance and biomass tended to be high increasing with chlorophyll *a* concentrations (Table 2). This was obvious for Lake Shinji, the enclosed embayment. Mesozooplankton abundance and biomass in Kagoshima Bay were medium compared with those at other coastal sites. Mesozooplankton revealed a similar community

structure between Kagoshima Bay and Ise Bay (Uye et al., 2000a); i.e. small calanoids were the predominant group at vertically mixing stations (March in Kagoshima Bay vs. offshore stations in Ise Bay) and poecilostomatoids were abundant at thermally stratified stations (June to November in Kagoshima Bay vs. inside stations in Ise Bay).

In Kagoshima Bay, calanoids occurred abundantly in March but poecilostomatoids dominated mesozooplankton community in June to November (Fig. 4). Our results were inconsistent with a previous study that paracalanid and cen-

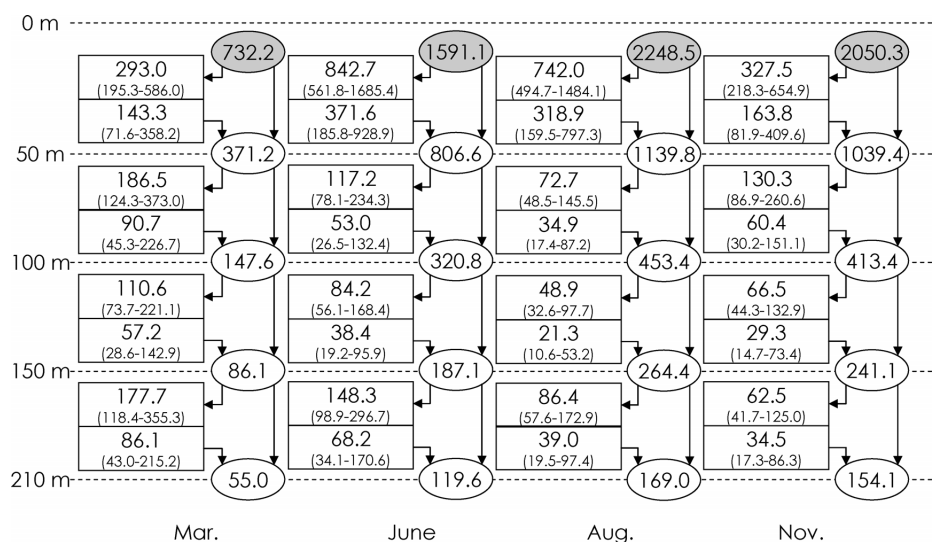

Figure 7. Schematic diagram showing ingestion rate (upper box: $\text{mg C m}^{-2} \text{ day}^{-1}$) of particle-feeding mesozooplankton, egestion rate (lower box: $\text{mg C m}^{-2} \text{ day}^{-1}$) of total mesozooplankton and particulate organic carbon flux (open circle: $\text{mg C m}^{-2} \text{ day}^{-1}$) in the 0–210 m water column via four layers at Station A in Kagoshima Bay. Primary production (shaded circle: $\text{mg C m}^{-2} \text{ day}^{-1}$) is estimated backward from POC flux at 150 m which was measured from sediment trap samples. Numbers in parentheses at each box are maximum and minimum of ingestion rate of particle-feeding metazoans and egestion rate of total mesozooplankton.

tropagid copepods were predominant and oncaeid and corycaeid copepods were not so abundant during summer (Nozawa and Saisyo, 1980). However, it is common that oncaeid (or poecilostomatoid) copepods increase their abundance toward summer in Toyama Bay (Takahashi and Uchiyama, 2008), Inland Sea of Japan (Hirota, 1980) and Sagami Bay (Shimode et al., 2006). According to the sampling methodology of Nozawa and Saisyo (1980), mesozooplankton samples were collected using a plankton net with 0.33-mm mesh opening from 50 m or using a net with 0.1-mm mesh opening from 5 m. In our samples, most of poecilostomatoid copepods appeared in the size-class smaller than 0.5 mm (Fig. 4). This indicates that smaller copepods are not efficiently collected for the previous study in Kagoshima Bay. Therefore, we can say that smaller copepods, especially poecilostomatoids, are typical for mesozooplankton community during the thermal stratified period in Kagoshima Bay. Since size-class smaller than 0.5 mm composed more than half of mesozooplankton biomass (Figs. 3 and 5), smaller copepods also determine the seasonal changes of mesozooplankton abundance and biomass during June to November in Kagoshima Bay.

In Toyama Bay, diel vertical migration was evident for mesozooplankton community which calanid copepods were predominant (Takahashi and Hirakawa, 2001). In Kagoshima Bay, diel vertical migration was obscure and metazoans concentrated at the surface throughout the day in June, August and November (Figs. 5 and 6). Poecilostomatoid

copepods are known to carry out no day–night migration at subtropical site (Steinberg et al., 2008a). Nozawa and Saisyo (1980) also mentioned that diel vertical migrations were obscure for oncaeid copepods in Kagoshima Bay. Since oncaeids were the most predominant group (Table 2), surface concentrations of mesozooplankton community during June to November are clearly associated with the predominance of the small copepods. Excepted for March, a diurnally vertical migration seems to be evident for metazoans larger than 0.5 mm due to the high biomass above 50 m in nighttime and below 150 m in daytime (not shown in figure). This might be responsible for overestimation of mesozooplankton feeding on POC flux.

In our box model for mesozooplankton ingestion and egestion, we used 0.3 of gross growth efficiency and 0.6 assimilation efficiency (see Methods). Since these numbers are known to be variable among the species (Omori and Ikeda, 1976), we evaluated our estimates using sensitivity analysis and validation with the other estimates. Based on the simultaneously microscopic analyses for sediment trap samples (Kobari et al., 2010), fecal pellet flux at 150 m was estimated to be 40.9 in March, 28.3 in June, 4.3 in August and 26.6 $\text{mg C m}^{-2} \text{ day}^{-1}$ in November. As our estimates using moderate gross growth and assimilation efficiencies were comparable to these observed numbers (Fig. 7), our box model is considered to follow the seasonal pattern of mesozooplankton ingestion and egestion.

In semi-enclosed embayment, hypoxia is generally

found in summer when stratification was the most developed and phytoplankton biomass was the highest (Fujiwara et al., 2000; Takahashi et al., 2000; Tsutsumi et al., 2007). Tsutsumi et al. (2007) pointed out that hypoxia at depth was formed by the consumption of dissolved oxygen during bacterial decomposition of sinking phytoplankton aggregates in Ariake Bay. Different from these studies, in Kagoshima Bay, chlorophyll *a* concentrations in November were higher than those in August (Fig. 2). Kobari et al. (2009) suggested that autumn increase of chlorophyll was resulted from high nutrients due to the enhanced vertical mixing. Corresponding to the high chlorophyll, POC fluxes at 150 m in August and November was higher than those in March and June (Fig. 7). In August and November, mesozooplankton feeding impacts on primary production was estimated to be 33% and 16%, respectively. Then, why the feeding impacts of mesozooplankton community were such low, even though particle feeders accounted for more than 65% of mesozooplankton abundance and concentrated in 0–50 m layer? As described above, small poecilostomatoids (mostly *Oncaea* spp.) were predominant among mesozooplankton abundance and biomass in August and November (Figs. 5 and 6, Table 2). It is reported that nano-sized phytoplankton and microbes are major food items for these poecilostomatoids (Wu et al., 2004). In Kagoshima Bay, micro-sized phytoplankton cells contributed to high chlorophyll *a* in November (Fig. 2). However, these phytoplankton cells would be too large to be ingested by poecilostomatoids. Therefore, we conclude that the high POC fluxes in August and November are resulted from the sinking aggregates of large phytoplankton cells which are not effectively removed by small copepods. This might be one of the provable explanations for hypoxia at depth formed during summer to autumn in Kagoshima Bay.

Acknowledgements

We are grateful to Dr. J. Ishizaka and two anonymous reviewers for valuable comments on our data analysis. We thank the crews of T/S “Nansei-Marū” and “Kagoshima-Marū” for help with oceanographic observations, plankton samplings and trap deployments. A part of the present study was supported by grants from the Japan Society for the Promotion of Science (18681003, 21710012) and from Kagoshima University.

References

- Aizawa, Y. (1980) Plankton in Otsuchi Bay. *Kaiyo Monthly*, **12**, 625–633. (in Japanese)
- Buesseler, K. O., C. H. Lamborg, P. W. Boyd, P. J. Lam, T. W. Trull, R. R. Bidigare, J. K. B. Bishop, K. L. Casciotti, F. DeHairs, D. M. Karl, D. Siegel, M. W. Silver, D. K. Steinberg, J. Valdez, B. Van Mooy and S. E. Wilson (2007) Revisiting carbon flux through the ocean’s twilight zone. *Science*, **316**, 567–570.
- Carroll, M. L., J. C. Miquel and S. W. Fowler (1998) Seasonal patterns and depth-specific trends of zooplankton fecal pellet fluxes in the Northwestern Mediterranean Sea. *Deep-Sea Res. I*, **45**, 1303–1318.
- Chihara, M. and M. Murano (1997) An Illustrated Guide to Marine Plankton in Japan. Tokai University Press, Tokyo, 1574 pp. (in Japanese)
- Fowler, S. W. and G. A. Knauer (1986) Role of large particles in the transport of elements and organic compounds through the oceanic water column. *Prog. Oceanogr.*, **16**, 147–194.
- Fujiwara, T., T. Takahashi, Y. Yamada and A. Kaneko (2000) Response of hypoxic water mass in Tokyo Bay to the variation in hydrographic condition outside of the Bay. *Oceanogr. Japan*, **9**, 303–313. (in Japanese with English abstract)
- Gnaiger, E. (1983) Calculation of energetic and biochemical equivalents of respiratory oxygen consumption. In: *Polarographic Oxygen Sensors*, Gnaiger, E. and H. Forstner, (Eds.), Springer, Berlin, 337–345.
- González, H. E. and V. Smetacek (1994) The possible role of the cyclopoid copepod *Oithona* in retarding vertical flux of zooplankton fecal material. *Mar. Ecol. Prog. Ser.*, **113**, 233–246.
- Hirota, R. (1980) Zooplankton in Inland Sea. *Kaiyo Monthly*, **12**, 730–737. (in Japanese)
- Huskin, I., L. Viesca and R. Anadón (2004) Particle flux in the Subtropical Atlantic near the Azores: influence of mesozooplankton. *J. Plankton Res.*, **26**, 403–415.
- Ikeda, T. (1985) Metabolic rates of epipelagic marine zooplankton as a function of body mass and habitat temperature. *Mar. Biol.*, **85**, 1–11.
- Iversen, M. H. and L. K. Poulsen (2007) Coprorhexy, coprophagy, and coprochaly in the copepods *Calanus helgolandicus*, *Pseudocalanus elongatus*, and *Oithona similis*. *Mar. Ecol. Prog. Ser.*, **350**, 79–89.
- Kobari, T., H. Akamatsu, M. Minowa, T. Ichikawa, K. Iseki, R. Fukuda and M. Higashi (2010) Effects of the copepod community structure to fecal pellet flux in Kagoshima Bay, a deep, semi-enclosed embayment. *J. Oceanogr.*, **66**, 673–684.
- Kobari, T., Y. Kobari, T. Ichikawa, Y. Kugita, T. Yoshida, T. Fujii, S. Furuhashi, T. Yamamoto, A. Habano and R. Fukuda (2009) Seasonal dynamics of microbial plankton community in Kagoshima Bay. *Aquabiology*, **31**, 37–44. (in Japanese with English abstract)
- Kobari, T., D. K. Steinberg, A. Ueda, A. Tsuda, M. W. Silver and M. Kitamura (2008) Impacts of ontogenetically migrating copepods on downward carbon flux in the western subarctic Pacific Ocean. *Deep-Sea Res. II*, **55**, 1648–1660.
- Lampitt, R. S., T. Noji and B. von Bodungen (1990) What happens to zooplankton fecal pellets? Implications for material flux. *Mar. Biol.*, **104**, 15–23.
- Martin, J. H., G. A. Knauer, D. M. Karl and W. W. Broenkow (1987) VERTEX: carbon cycling in the northeast Pacific. *Deep-Sea Res. A*, **34**, 267–285.
- Nozawa, K. and T. Saisyo (1980) Plankton in Kagoshima Bay. *Kaiyo Monthly*, **12**, 654–672. (in Japanese)
- Omori, M. and T. Ikeda (1976) *Zooplankton Ecology Research Method*. Kyoritsu Publication, 229 pp. (in Japanese)
- Otsuka, S. and S. Nishida (1997) Reconsideration on feeding habits of marine pelagic copepods (Crustacea). *Oceanogr.*

- Japan, **6**, 299–320. (in Japanese with English abstract)
- Peters, R. H. and J. A. Downing (1984) Empirical analysis of zooplankton filtering and feeding rates. *Limnol. Oceanogr.*, **294**, 763–784.
- Poulsen, L. K. and T. Kiørboe (2006) Vertical flux and degradation rates of copepod fecal pellets in a zooplankton community dominated by small copepods. *Mar. Ecol. Prog. Ser.*, **323**, 195–204.
- Sasaki, H., H. Hattori and S. Nishizawa (1988) Downward flux of particulate organic matter and vertical distribution of calanoid copepods in the Oyashio Water in summer. *Deep-Sea Res. I*, **35**, 505–515.
- Shimode, S., T. Toda and T. Kikuchi (2006) Spatio-temporal changes in diversity and community structure of planktonic copepods in Sagami Bay, Japan. *Mar. Biol.*, **148**, 581–597.
- Silver, M. W. and M. M. Gowing (1991) The “particle” flux: origins and biological components. *Prog. Oceanogr.*, **26**, 75–113.
- Steinberg, D. K., J. S. Cope, S. E. Wilson and T. Kobari (2008a) A comparison of mesopelagic mesozooplankton community structure in the subtropical and subarctic North Pacific Ocean. *Deep-Sea Res. II*, **55**, 1615–1635.
- Steinberg, D. K., B. A. S. Van Mooy, K. O. Buesseler, P. W. Boyd, T. Kobari, and D. M. Karl (2008b) Bacterial vs. zooplankton control of sinking particle flux in the ocean’s twilight zone. *Limnol. Oceanogr.*, **53**, 1327–1338.
- Suzuki, R. and T. Ishimaru (1990) An improved method for the determination of phytoplankton chlorophyll using *N, N*-dimethylformamide. *J. Oceanogr. Soc. Japan*, **46**, 190–194.
- Svensen, C. and J. C. Nejtgaard (2003) Is sedimentation of copepod faecal pellets determined by cyclopoids? Evidence from enclosed ecosystems. *J. Plankton Res.*, **25**, 917–926.
- Takahashi, T., T. Fujiwara, M. Kuno and Y. Sugiyama (2000) Seasonal variation in intrusion depth of oceanic water and the hypoxia in Ise Bay. *Oceanogr. Japan*, **9**, 265–271. (in Japanese with English abstract)
- Takahashi, T. and K. Hirakawa (2001) Day-night vertical distribution of the water and spring copepod assemblage in Toyama Bay, southern Japan Sea, with special reference to *Metridia pacifica* and *Oithona atlantica*. *Bull. Plakton Soc. Japan*, **48**, 1–13. (in Japanese with English abstract)
- Takahashi, T. and I. Uchiyama (2008) Seasonal changes in the density and vertical distribution of nauplii, copepodites and adults of the genera *Oithona* and *Oncaea* (Copepoda) in the surface water of Toyama Bay, southern Sea of Japan. *Plankton Benthos Res.*, **3**, 143–151.
- Terazaki, M. and C. Tomatsu (1997) A vertical multiple opening and closing plankton sampler. *J. Adv. Mar. Sci. Tech. Soc.*, **3**, 127–132.
- Thuesen, E. V., C. B. Miller and J. J. Childress (1998) Ecophysiological interpretation of oxygen consumption rates and enzymatic activities of deep-sea copepods. *Mar. Ecol. Prog. Ser.*, **168**, 95–107.
- Tsutsumi, H., A. Tsutsumi, A. Takamatsu, C. Kimura, S. Nagata, M. Tsukuda, T. Komorita, T. Takahashi and S. Montani (2007) Mechanisms for the expansion of hypoxic water in the inner areas of Ariake Bay during summer. *Oceanogr. Japan*, **16**, 183–202. (in Japanese with English abstract)
- Turner, J. T. (2002) Zooplankton fecal pellets, marine snow and sinking phytoplankton blooms. *Aquat. Microb. Ecol.*, **27**, 57–102.
- Uye, S., N. Nagano and T. Shimazu (2000a) Abundance, biomass, production and trophic roles of micro- and net-zooplankton in Ise Bay, central Japan, in winter. *J. Oceanogr.*, **56**, 389–398.
- Uye, S. and T. Shimazu (1997) Geographical and seasonal variations in abundance, biomass and estimated production rates of meso- and macrozooplankton in the Inland Sea of Japan. *J. Oceanogr.*, **53**, 529–538.
- Uye, S., T. Shimazu, M. Yamamuro, Y. Ishitobi and H. Kamiya (2000b) Geographical and seasonal variations in mesozooplankton abundance and biomass in relation to environmental parameters in Lake Shinji-Ohashi River-Lake Nakaumi brackish-water system, Japan. *J. Mar. Sys.*, **26**, 193–207.
- Welschmeyer, N. A. (1994) Fluorometric analysis of chlorophyll *a* in the presence of chlorophyll *b* and phaeopigments. *Limnol. Oceanogr.*, **39**, 1985–1992.
- Wu, C., J. Hwang and J. Yang (2004) Diets of three copepods (Poecilostomatoida) in the southern Taiwan Strait. *Zool. Studies*, **43**, 388–392.
- Yamaguchi, A., Y. Watanabe, H. Ishida, T. Harimoto, K. Furusawa, S. Suzuki, J. Ishizaka, T. Ikeda and M. M. Takahashi (2002) Community and trophic structures of pelagic copepods down to greater depths in the western subarctic Pacific (WEST-COSMIC). *Deep-Sea Res. I*, **49**, 1007–1025.
- Zaitsev, Yu. P. (1992) Recent changes in the trophic structure of the Black Sea. *Fish. Oceanogr.*, **1**, 180–189.
- Zhang, X. and H. G. Dam (1997) Downward export of carbon by diel migrant mesozooplankton in the central equatorial Pacific. *Deep-Sea Res. II*, **44**, 2191–2202.

鹿児島湾におけるメソ動物プランクトン群集の豊度，バイオマス，鉛直分布の季節変化

蓑輪 政人¹，小針 統^{1†}，赤松 弘康¹，市川 敏弘²，福田 隆二³，東 政能⁴

メソ動物プランクトンが粒状有機炭素（POC）の沈降フラックスに与える影響を評価するために，鹿児島湾におけるメソ動物プランクトンの個体数密度，バイオマス，鉛直分布の季節変化を調べた。クロロフィル a 濃度は3月では低かったが，マイクロサイズが卓越した8月と11月には 1 mg m^{-3} 以上となった。メソ動物プランクトンのバイオマスと個体数密度は3月には水柱全体に一様に分布していたが，他の月では50m以浅に集中していた。3月において2mm以上のメソ動物プランクトンがバイオマスで卓越し

ており，最優占群はカラヌス目カイアシ類であった。他の月では0.5mmより小さいメソ動物プランクトンが優占し，ポエキロストム目カイアシ類が最も優占する分類群であった。ボックスモデルによると，POCフラックスが高かった8月と11月には，メソ動物プランクトンの摂餌は基礎生産の16–33%であった。これらの結果は，8月と11月にPOCフラックスが高くなるのは，小型カイアシ類によって効率的に除去されない大型植物プランクトンの沈降凝集塊によることを示している。

2010年5月30日受付，2010年12月28日受理

¹ 鹿児島大学水産学部水産生物・海洋学分野，〒890-0056 鹿児島県鹿児島市下荒田4-50-20

² 鹿児島大学理学部地球環境科学科，〒890-8580 鹿児島県鹿児島市郡元1-21-24

³ 鹿児島大学水産学部附属練習船南星丸，〒890-0056 鹿児島県鹿児島市下荒田4-50-20

⁴ 鹿児島大学水産学部附属練習船かごしま丸，〒890-0056 鹿児島県鹿児島市下荒田4-50-20

† kobari@fish.kagoshima-u.ac.jp